

THE EFFECT OF FINANCIAL PERFORMANCE AND FIRM SIZE ON BOND RATINGS

Siti Pujiwati

Universitas Pekalongan, Faculty of Economics and Business, Indonesia, Jl. Sriwijaya No. 3, Pekalongan, Indonesia, sitipujiwati43@gmail.com

Mahirun Mahirun

Universitas Pekalongan, Faculty of Economics and Business, Indonesia, Jl. Sriwijaya No. 3, Pekalongan, Indonesia, mahirun@yahoo.com (Corresponding Author)

Arih Jannati

Universitas Pekalongan, Faculty of Economics and Business, Indonesia, Jl. Sriwijaya No. 3, Pekalongan, Indonesia, arih.jannati@gmail.com

Abstract: This study aims to test and analyze the factors that influence bond ratings involving variables of profitability, liquidity, leverage, activity ratio, and firm size in banking firm listed on the indonesia stock exchange for the period 2017-2021. The analytical tool we use is logistic regression. The findings in this study are that the activity ratio proxied by total asset turnover and firm size has a positive and significant effect. Meanwhile, another finding of our research is that liquidity with the current ratio indicator also has a positive although insignificant effect on bond ratings. Meanwhile, leverage using the debt to equity ratio indicator and profitability with the return on assets indicator have a negative and insignificant.

Keywords : *Return On Assets, Current Ratio, Debt to Equity Ratio, Total Asset Turnover, Firm Size, Bond Ratings*

1. Introduction

Signaling theory according to Brigham & Houtson (2019), is an action taken by firm management that provides clues to investors about how management views the firm's prospects. Signaling theory is a theory that explains the rise and fall of stock prices in the market, so that it will influence investor decisions. However, there is still information asymmetry between firm and investors and creditors, making it difficult for third parties to provide accurate assessments of firm performance and provide assessments related to prospects and quality. Bonds are one of the securities that investors can choose besides stocks, because bonds can provide fixed income for investors. Bonds themselves are attractive assets, besides that in recent years the bond market has received more attention, due to the increasing value of bond trading (Pandutama, 2012). In most cases, bond regulators declare a business insolvent and force it to file for bankruptcy if bond interest is not paid. According to Dewi & Utami (2020) bondholders are more likely to pay interest than common or preferred stocks, which pay dividends at the discretion of management.

The description of the bond issuer's ability to repay debt and interest related to the bonds offered, the bonds are rated. A high bond rating indicates that the signal that will be received by investors is a good signal. Bonds are the right choice for issuers because it allows them to obtain funds for their operational purposes without having to go through many steps such as applying for credit to financial institutions. According to Khalqi (2018) the firm issues bonds is to obtain funds for financing the firm's operations.

A bond rating is an assessment of the creditworthiness of a bond issuer based on relevant risk factors. Ratings do not imply a recommendation to buy, sell or hold a bond. This opinion focuses on the capacity and willingness of the bond issuer to fulfill its obligations in a timely manner (Nurhariyaningsih & Nazar, 2020).

When compared to investing in stocks, Indonesian bond ownership is still very small. Bonds offers a number of advantages, one of which is the ability to receive yields. Bondholders receive income from dividends and capital gains when interest payments are made. Another advantage is that bondholders will take precedence over shareholders when it comes to guaranteeing the return of loans to the business. Despite the fact that there are risks involved, bonds are considered a safe investment. The risk of bonds is that the firm fails to pay its obligations to investors or is unable to repay its bonds (default risk). When buying bonds, investors should consider the bond rating among other factors. The firm's ability to fulfill its future obligations is the bond rating. Investors can see how safe a bond is on this scale.

The rating given to a bond is a security given to the bond rating agency. PT Pameringkat Efek Indonesia (PT. PEFINDO) is an Indonesian bond rating agency, established in 1993, PT. PEFINDO has evaluated more than 500 businesses and local governments. Rating agencies only evaluate the occurrence of an event and do not monitor the firm's financial performance on a daily basis, which is why they issue bonds. (Oktaviyani, 2021). Meanwhile, Moody's and Standard & Poor's are responsible for international bond ratings. Bonds usually fall into one of two categories: investment grade (AAA, AA, A, and BBB) and non-investment grade (BB, B, CCC, and D). For a bond to be worth investing in, it must fall into the investment grade category if the firm is considered to have sufficient funding sources to fulfill its obligations. Conversely, bonds that fall into the non-investment grade category are not worth investing in because the firm does not have much funding available to pay off its obligations.

The financial performance of a firm is an achievement achieved by the firm in a certain period that reflects the health level of the firm. According to Ela & Sumartono [7] evaluation of the management of firm assets by firm management is provided by financial performance measurements. Financial factors such as profitability, liquidity, *leverage*, activity and firm size can have an impact on high and low bond ratings, as stated in the requirements (Sulistiani & Meutia, 2021). A firm receives a higher rating due to the low risk of bankruptcy (*default*) associated with its higher level of profitability. A ratio called profitability is used to determine how effective a firm is overall based on how much money it will spend and make from sales or investments. According to Dewi & Sudiarta (2018) profitability examines the extent to which the investment invested is able to provide the expected return. The firm's profit position and asset utilization increase with higher ROA. Nuriman & Nurdiyansyah (2021) and Rivandi & Gustiyani (2021), state that profitability is considered to have a significant positive effect on bond ratings. Meanwhile, research Darmawan et al. (2020) and Sulistiani & Meutia (2021) state that profitability has a negative effect on bond ratings.

Liquidity can affect the bond rating, because the firm's ability to pay short-term debt will reduce the risk of bond default. According to research results Mardiana & Suryandani (2021) and Kustiyaningrum et al. (2017) shows that liquidity has a positive effect on bond ratings. Meanwhile, research Sulistiani & Meutia (2021) and Nuriman & Nurdiyansyah (2021) shows that liquidity has a negative effect on bond ratings. Besides liquidity, a measure of the firm's ability to pay off its total debt can also affect the bond rating. *Leverage* states debt policy, so debt can be used to estimate the benefits that are likely to be obtained for investors if they invest in a firm. aDarmawan et al. (2020) and

Mardiana & Suryandani (2021) stated that *leverage has a significant positive effect on bond ratings*. Meanwhile, research Kustiyaningrum et al. (2017) and Rivandi & Gustiyani (2021) state that *leverage has a negative effect on bond ratings*.

The ratio of the level of efficiency (effectiveness) of the utilization of firm resources or the ratio to assess the firm's ability to carry out its daily activities also affects the bond rating. Based on research conducted by Herlinasari (2021) and Setiawan et al. (2022) a stated that activity has a positive effect on bond ratings. Meanwhile, research from Esensia et al. (2020) states that activity proxied by TATO has a negative effect on bond ratings. Another variable that can affect bond ratings is firm size. According to Rezky (2013) asserts that large businesses are less risky than small businesses because small businesses face greater risks. In addition, the potential to diversify non-systematic risk is also getting bigger so that the firm's bond risk decreases. Firm size describes the category of *investment grade* or *non-investment grade* firm. Because the size of the firm is assessed from published information. The larger the size of the firm means that more investors can get a lot of information easily and reduce the uncertainty that investors have so that it can improve the firm's bond rating. According to Darma & Sulistiyani (2020) increasing the firm's bond rating requires investors to access more information and reduce their level of uncertainty. According to Darmawan et al. (2020) and Sulistiani & Meutia (2021) and state that firm size has a positive effect on bond ratings.

This study aims to test and analyze the factors that influence bond ratings involving variables of profitability, liquidity, *leverage*, activity, and firm size in banking firm on the Indonesia Stock Exchange in 2017-2021. Banking firm were chosen in our study, because as a financial institution whose main function is to intermediate funds, trust from the public is the main driving factor. On the other hand, with the strict supervision of the Indonesian government on the financial sector, it is very interesting for us to further examine how the impact of banking financial performance on bond ratings, as a reference for parties with an interest in banking.

1.1. Profitability and Bond Rating

Firm with high profits are considered capable of running their business well and have more potential to maintain their business continuity in the long term, so they will have a greater ability to fulfill their obligations than firm with low profits. Return on assets is used to measure management's ability to earn profits and reflects the managerial ability to manage the firm as a whole. The higher the level of Return on assets, the better the firm's rating will be (Lestari, 2019). With the firm making good profits, this shows that the firm is able to fulfill its obligations to investors in a timely manner. The study found that return on assets has a positive and significant effect on bond ratings (Angel & Sudjiman, 2020) (Dewi & Utami, 2020. Darmawan et al., 2020, Hung et al., 2021, Nuriman & Nurdiyansyah, 2021, Hafiz et al., 2021, Tambunan et al., 2023, and Azizah & Ady, 2023). Although other results show that Return on Assets has a positive and insignificant effect on bond rating (Risawati, 2020). and even according to Ruspriono & Marsoem (2021) shows that Return on Assets has a significant negative effect on bond rating, while Esensia et al. (2020) found a negative and insignificant direction of influence. Based on this description, the first hypothesis can be formulated as follows:

H1: Return on Asset has a positive and significant effect on Bond Rating

1.2. Liquidity and Bond Rating

Based on signaling theory, firm with healthy liquidity will provide interesting information and become attractive to investors compared to firm with poor liquidity,

thus avoiding information asymmetry between owners and stakeholders. Current Ratio is a liquidity ratio that measures the firm's ability to pay off its short-term obligations. The higher the firm's Current ratio, the better the firm's bond rating (adelia gufita, 2022). A high current ratio causes an increase in bond ratings because the firm has the ability to fulfill its short-term obligations in a timely manner, so the risk of default will be reduced (Prastiani, 2018). The study found that current ratio has a positive and significant effect on bond ratings (Kustiyaningrum et al., 2017, Utami et al., 2021, Mardiana & Suryandani, 2021, and Hung et al., 2021) The results of another study found that the current ratio has a positive although insignificant effect on bond rating (Dewi & Utami, 2020, Risawati, 2020, and Azizah & Ady, 2023). whereas Tambunan et al. (2023) found a negative although insignificant influence of the current ratio on bond rating. Based on this description, the second hypothesis can be formulated as follows:

H2: Current Ratio has a positive and significant effect on Bond Rating

1.3. Leverage and Bond Rating

The higher or lower the leverage ratio value means that only a small portion of the assets are financed with debt and the smaller the risk of firm failure, and vice versa, the lower the firm's leverage, the higher the rating of a firm. Firm with a low level of leverage tend to be favored by investors because investors have confidence that the firm will be able to pay off all its obligations when the debt is due. Debt to equity ratio is used to measure the firm's ability to pay off its obligations (Suprpto & Aini, 2019). The greater the Debt to equity ratio value indicates that the risk a firm has is high, while the lower the debt to equity ratio, the better the firm's rating and the higher the debt to equity ratio, the greater the risk of failure, which has an impact on the firm's burden on external parties. Based on research debt to equity ratio has a significant negative effect on bond ratings (Kaltsum & Anggraini, 2021, Sulistiani & Meutia, 2021, Rivandi & Gustiyani, 2021, and Ruspriono & Marsoem, 2021). Although there are also studies that find that debt to equity ratio has a significant positive effect on bond rating (Hung et al., 2021, and Azizah & Ady, 2023). Based on this, the third hypothesis is as follows:

H3: Debt to Equity Ratio has a negative and significant effect on Bond Rating

1.4. Activity and Bond Rating

Total Asset Turnover is an activity ratio that measures how efficiently a firm uses its assets to generate sales (Prastiani, 2018). The activity ratio assumes that there should be a proper balance between sales and assets owned by the firm. The purpose of the activity ratio is to measure how long it takes to collect receivables during one period, calculate the average collection of receivables, and how many times the funds invested in the working model. The higher the Total Asset Turnover, the firm's financial performance will improve. The results of the study state that total assets turnover has a positive and significant effect on bond ratings (Prastiani, 2018, Suharmadi & Suropto, 2021, Rosita et al., 2022, and A. Setiawan et al., 2022). Meanwhile, Ruspriono & Marsoem (2021) found a positive and insignificant effect of total assets turnover on bond ranking. Based on this, the fourth hypothesis is as follows:

H4: Total Asset Turnover has a positive and significant effect on Bond Rating.

1.5. Firm Size and Bond Rating

Signal theory and prospect theory explain that the size of a firm will affect corporate governance. firm have a large asset capacity, it can be predicted that the firm has good governance and can generate large profits within a certain period of time. A large firm

will show that the firm has large assets so that it is a good sign for investors (Sulaksono & Sandra, 2022). This makes investors able to know the ability to pay bond interest and pay off principal loans which can increase the firm's bond rating (ISetiawan & Mahardika, 2019). According to research firm size has a positive and significant effect on bond ratings (Sri & Dwi, 2009, Risawati, 2020, Darmawan et al., 2020, Sulistiani & Meutia, 2021, and Suharmadi & Suropto, 2021). While Tambunan et al. (2023) produces a positive although insignificant direction of influence from firm size on bond rating. Based on this, the fifth hypothesis is:

H5: Firm Size has a positive and significant effect on Bond Rating

2. Methodology

2.1. Data Collection and Sources

The type of data in this study is secondary data, with the data source used coming from the financial statements of banking firm on the Indonesia Stock Exchange in 2017-2021. This research data is panel data, which is a type of data that is a combination of *cross sectional* data and *time series* data (Gujarati, 2003). Regression analysis is used to answer research objectives with return as the dependent variable.

2.2. Empirical Model and Variable Measurement

The focus of the research is on empirical testing of the integration of variables related to Bond Rating which includes Return On Assets (ROA), Current Ratio (CR), Debt to Equity Ratio (DER), Total Asset Turnover (TATO), and Firm Size. The empirical study model is presented in Figure 1.

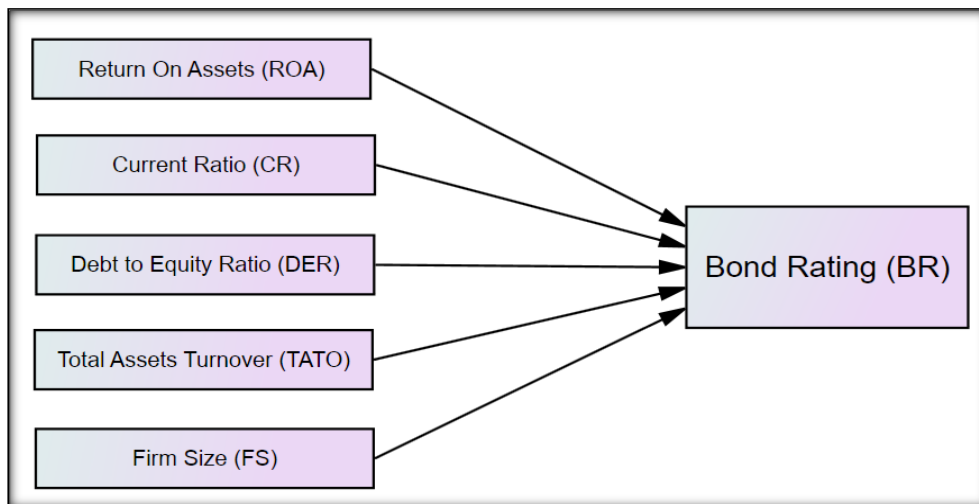

Figure 1. Empirical Research Model

In Figure 1, an equation can be formed that shows the causal relationship between ROA, CR, DER, TATO, and FS variables with bond rating variables, as follows:

$$BR = \beta_1ROA + \beta_2CR + \beta_3DER + \beta_4TATO + \beta_5FS + \varepsilon_1$$

Where:

BR = bond rating

ROA = return on equity

CR = Current ratio

DER = debt to equity ratio

TATO = total assets turnover

FS = firm size

Return on Assets is used as an indicator of profitability (Esensia et al., 2020, Hung et al., 2021, and Mahirun et al., 2023). Current ratio is used as a proxy for liquidity variables (Dewi & Utami, 2020, Esensia et al., 2020, Hung et al., 2021, Ruspriono & Marsoem, 2021, Azizah & Ady, 2023, and Tambunan et al., 2023). Debt to equity ratio is used as an indicator of Leverage (Mahirun, 2019, Hung et al., 2021, Ruspriono & Marsoem, 2021, and Azizah & Ady, 2023). Total Asset Turnover is used as an indicator of the activity ratio (Suharmadi & Suropto, 2021, Ruspriono & Marsoem, 2021, Rosita et al., 2022, and Setiawan et al., 2022). The natural logarithm of total assets is used as an indicator of firm size (Risawati, 2020, Suharmadi & Suropto, 2021, and Tambunan et al., 2023). The bond rating from PT Pameringkat Efek Indonesia (PT. PEFINDO) is used as a bond rating indicator (Dewi & Utami, 2020, Esensia et al., 2020, Suharmadi & Suropto, 2021, Hung et al., 2021, and Azizah & Ady, 2023).

3. Result and discussion

3.1. Descriptive statistics

The firm used as the object of research is a banking firm listed on the Indonesia Stock Exchange for the period 2017-2021. Based on the criteria needed in the study, firm that qualify as samples amounted to 85. The results of the descriptive statistical test obtained the average bond rating reached 0.76, the highest bond rating was 1, and the lowest was 0. The average return on assets reached 0.0098%, the highest reached 0.03%, and the lowest was -0.04% (table 3).

Table 3. Descriptive Statistics Test Results

Variable	N	Minimum	Maximum	Mean	Std. Deviation
Return On Assets	85	-0.04	0.03	0.0098	0.01059
Current Ratio	85	0.16	1.06	0.3235	0.21451
Debt to Equity Ratio	85	0.01	17.07	6.5742	2.90646
Total Asset Turnover	85	0.00	0.09	0.0479	0.01833
Firm Size	85	29.13	35.08	32.6777	1.51053
Bond Rating	85	0	1	0.76	0,4270

Source: SPPS data processing results

3.2. Overall Model Fit Test Results (Overall Model Test)

The overall model fit test is shown in Table 4 and Table 5.

Table 4. Results of Overall Model Fit Test Block Number =0

Iteration History ^{a,b,c}			
Iteration		-2 Log likelihood	Coefficients
			Constant
Step 0	1	92.975	1.059
	2	92.751	1.175
	3	92.751	1.179

4	92.751	1.179
---	--------	-------

Source: *SPPS data processing results*

Based on table 2 and table 3, the resulting $-2\log L$ value (block number = 0) is 92.751, after entering the variables of Profitability, Liquidity, Leverage, Activity and Firm size, the $-2\log L$ value (block number = 1) is 35.026. This shows that the $-2\log L$ value at the beginning has decreased by 57.725, so the regression model shows a good regression model or in other words the hypothesized model fits the data.

Table 5. Overall Model Fit Test Result Block Number = 1

Iteration History ^{a,b,c,d}							
Iteration		-2 Log likelihood	Coefficients				
			Constant	Return on Assets	Current Ratio	Debt to Equity Ratio	Total Assets Turnover
Step 1	1	56.473	-8.657	-26.078	-0.834	-0.030	57.822
	2	43.715	-16.523	-47.460	-0.725	-0.048	100.717
	3	38.130	-27.530	-64.520	0.855	-0.086	139.877
	4	35.612	-42.048	-77.821	3.281	-0.151	176.477
	5	35.064	-51.842	-88.899	4.558	-0.196	205.313
	6	35.026	-55.167	-92.757	4.971	-0.211	215.668
	7	35.026	-55.456	-93.090	5.006	-0.212	216.582
	8	35.026	-55.458	-93.092	5.006	-0.212	216.588
	9	35.026	-55.458	-93.092	5.006	-0.212	216.588

Source: *SPPS data processing results*

3.3. Testing Model Feasibility (Hosmer and Lemeshow)

Testing the feasibility of regression with Hosmer and Lemeshow is carried out with the aim of testing the hypothesis whether the empirical data fits or fits the model. If the significant value (<0.05) then the hypothesis is rejected, meaning that there is a significant difference between the model and its observation value. If the significant value (>0.05) then the hypothesis is accepted, meaning that the model fits the observation value (Pefindo, 2020).

Table. Hosmer and Lemeshow Test Result

Hosmer and Lemeshow Test			
Step	Chi-square	df	Sig.
1	1.719	7	0.974

Source: *SPPS data processing results*

Based on table 6, the Hosmer and Lemeshow test results show that the Chi-square value is 1.719 with a significant value of 0.974. This means that the significant value of $0.974 > 0.05$, then the observation or in other words the model can be accepted because it is in accordance with the observation data.

3.4. Coefficient of Determination (Nagelkerke's R Square)

Nagelkerke's R-Square is a modification of the Cox and Snell coefficient to ensure that its value varies from 0 to 1. Nagelkerke's R-Square is used to obtain a coefficient of determination that can be interpreted. The following is the coefficient of determination (Nagelkerke's R Square) in table 7.

Table 7. Nagelkerker's R Square Test Result

Model Summary			
Step	-2 Log likelihood	Cox & Snell R Square	Nagelkerke R Square
1	35.026 ^a	0.493	0.742

Source: *SPPS data processing results*

Based on table 7, the Cox and Snell R Square value is 0.493 and the Nagelkerke's R Square value is 0.742. These results indicate the variability of the dependent variable which can be explained by the variability of the independent variable by 74.2%. This means that in this study the variables of Profitability, Liquidity, Leverage, Activity and Firm size can explain the Bond Rating as the dependent variable by 74.4% and the remaining 25.7% is explained by other variables not used in the study.

3.5. Classification Matrix Test

This test is used to clarify the description of the prediction of the logistic regression model with observational data. The classification table shows the predictive power of the regression model to predict the likelihood of a firm getting a bond rating of either High Investment or Low Investment.

Table 8. Classification Matrix Test Result

Classification Table ^a					
Observed		Predicted			
		Peringkat Obligasi		Percentage Correct	
		Low Investment	High Investment		
Step 1	Peringkat Obligasi	Low Investment	14	6	70.0
		High Investment	6	59	90.8
Overall Percentage					85.9

Source: *SPPS data processing results*

Based on table 8, of the 20 firm in the Low Investment category that correctly get the Low Investment Bond Rating category there are 14 firm, while 6 firm are in the High Investment category with a value for the correctness rate of firm with Low Investment is 70%. Meanwhile, out of 65 firm in the High Investment category that are correctly categorized as High Investment, there are 59, while the other 6 firm are categorized as Low Investment with the correct classification rate for firm experiencing High Investment is 90.8%. The overall prediction accuracy of this model is 85.9%.

3.6. Logistic Regression Model Analysis

Hypothesis testing is carried out with logistic analysis with the aim of knowing the effect of the variables of Profitability, Liquidity, Leverage, Activity and Firm size both individually and simultaneously on the Bond Rating (table 9).

Table 9. Logistic Regression Model Analysis Result

		Variables in the Equation					
	Variable	B	S.E.	Wald	df	Sig.	Exp(B)
Step 1 ^a	Return on Assets	-93.092	53.681	3.007	1	0.083	0.000
	Current Ratio	5.006	3.453	2.102	1	0.147	149.300
	Debt to Equity Ratio	-0.212	0.158	1.804	1	0.179	0.809
	Total Assets Turnover	216.588	73.496	8.684	1	0.003	1.156E+94
	Firm Size	1.535	0.654	5.509	1	0.019	4.643
	Constant	-55.458	21.919	6.402	1	0.011	0.000

Source: SPSS data processing results

The regression equation model that can be written based on the test results in table 9 in the form of a logistic regression equation is as follows:

$$BR = -55,458 - 93,092 (ROA) + 5,006(CR) - 0,212(DER) + 216,588(TATO) + 1,535(FS)$$

Where:

BR = bond rating

ROA = return on equity

CR = Current ratio

DER = debt to equity ratio

TATO = total assets turnover

FS = firm size

3.6.1. Test Results of the Effect of Profitability on Bond Rating

Based on the test results, the coefficient value is negative 93.092 and the significance value is 0.083, meaning that the return on assets variable has a negative and insignificant effect on the Bond Rating. The variable return on assets in this study is not able to improve the firm's bond rating. The firm's ability to generate profits is not necessarily able to improve the bond rating, although high profitability performance is a signal that the firm has bright prospects in generating profits. This is allegedly because the use of profit is prioritized for dividend payments, not for the repayment of long-term debt (bonds). Our findings support Esensia et al. (2020) and Sulistiani & Meutia (2021) found a negative and insignificant direction of influence of return on assets on bond rating, but did not support the results of research stating that return on assets has a significant positive effect on bond rating (Angel & Sudjiman, 2020, Dewi & Utami, 2020, Darmawan et al., 2020, Hung et al., 2021, Nuriman & Nurdiyansyah, 2021, Hafiz et al., 2021, Tambunan et al., 2023, and Azizah & Ady, 2023).

3.6.2. Test Results of Liquidity Effect on Bond Rating

Based on the results of hypothesis testing, the coefficient value is positive 5.006 and the significance value is 0.147, meaning that the current ratio has a positive and insignificant effect on the Bond Rating. The firm's current ratio increases, it will have little effect on the increase in bond rating. A high level of current ratio indicates the strong financial condition of the firm so that finance will affect the prediction of bond ratings. Firm that are able to fulfill their financial obligations on time can signal to investors that the firm is liquid and has assets greater than its current debt. The higher the current ratio, the better the bond rating given. The findings support research that finds the current ratio has a positive although insignificant effect on

bond rating [23, 24, 30, 31, 44]. However, it does not support research which states that Liquidity proxied by Current ratio has a positive and significant effect on Bond Rating (Kustiyaningrum et al., 2017, Utami et al., 2021, Mardiana & Suryandani, 2021, and (Hung et al., 2021).

3.6.3. Test Results of the Effect of Leverage on Bond Rating

Based on the results of hypothesis testing, the coefficient value is negative 0.212 and the significance value is 0.179, meaning that the Leverage variable has a negative and insignificant effect on Bond Rating. This indicates that high and low leverage has no effect on bond rating. Leverage shows the proportion of debt use in financing investment which is proxied by the debt to equity ratio, if the proportion of debt tends to have a low ability to fulfill its obligations. High leverage in a firm indicates that the firm's financial default risk is high. Not all firm with a high level of leverage will default because if the firm is able to manage the funds it borrows properly and correctly, the firm can generate profits, for example the firm uses the debt to add new products or open new factories so that the use of debt is able to generate profits that are likely to be greater than the loan (Idawati et al., 2018). This is because some firm in this study have guarantees or are guaranteed by their parent firm so that the bond rating is not based on financial ratios but rather on the firm that guarantees it. If the firm's debt is weak, it will be strengthened by the guarantee firm, so that the bond will be given the same rating as the guarantee firm. Our research results support the findings debt to equity ratio has a negative and insignificant effect on Bond Rating (Kustiyaningrum et al., 2017, Sulistiani & Meutia, 2021, and Rivandi & Gustiyani, 2021). However, it does not support research that states that the debt to equity ratio has a significant negative effect on bond ratings (Kaltsum & Anggraini, 2021, Sulistiani & Meutia, 2021, Rivandi & Gustiyani, 2021, and Ruspriono & Marsoem, 2021), and also found that debt to equity ratio has a significant positive effect on bond rating (Hung et al., 2021, and Azizah & Ady, 2023).

3.6.4. Test Results of the Effect of Activity on Bond Rating

Based on the test results, the coefficient value is positive 216.588 and the significance value is 0.003, meaning that total assets turnover has a positive and significant effect on Bond Rating. high activity tends to produce high bond ratings. The higher the firm's total asset turnover, the better the firm's ability to carry out firm activities in order to get maximum results to pay off its obligations. The firm's ability can be used as a positive signal that will attract investors. The research findings support research that finds that total assets turnover has a significant positive effect on bond ranking (Prastiani, 2018, Suharmadi & Suropto, 2021, Herlinasari, 2021, Rosita et al., 2022, and Setiawan et al., 2022). However, it does not support research that finds total assets turnover has a positive but insignificant effect on bond ranking (Ruspriono & Marsoem, 2021).

3.6.5. Test Results of Firm Size on Bond Rating

The results of hypothesis testing obtained a positive influence direction of 1.535 and a significant value of 0.019, meaning that Firm Size has a positive and significant influence on Bond Rating. Large firm are considered to have good prospects, are relatively more stable and more capable of generating profits than small firm. Large size firm are widely recognized by the public because the firm's ability to pay periodic interest and pay off the principal of its loans will also be better with the assets owned by the firm. firm that have high assets show that the firm has a large ability to fulfill each of the firm's obligations

and has collateral in the form of assets if the firm fails to fulfill its obligations, so that it will minimize default risk so that it can improve the bond rating of a firm. The study results are in accordance with research that found that bond ratings are positively and significantly influenced by firm size (Sri & Dwi, 2009, Setiawan & Mahardika, 2019, Risawati, 2020, Darmawan et al., 2020, Sulistiani & Meutia, 2021, and Suharmadi & Suropto, 2021). However, it does not support research Tambunan et al. (2023) which results in a positive although insignificant direction of influence from firm size on bond ranking.

4. Discussion

The findings place profitability does not affect the bond rating and even the direction is negative. The interesting thing is the assumption that the proportion of the use of profits generated by the firm is not used in funding cash flow or long-term debt (bonds) but is used to pay dividends to investors whose nominal value is greater. So the profit is not used to pay financial obligations related to bonds, resulting in profitability has no effect on bond ratings. That way PT PEFINDO in examining the rating of a bond not only looks at the firm's ability to generate high profits but by assessing the management of current assets and liabilities. This is evidenced by the test results which show that the level of effectiveness of the firm in optimizing its assets to create sales is a factor that has a positive and significant impact in determining the bond rating.

5. Conclusion and implications

5.1. Conclusion

The main result of our research is that total assets turnover and firm size have a positive and significant effect on bond rating. This indicates that the more effective and efficient the use of assets to create sales and supported by the strength of the firm to obtain access to funding because of the large size of the firm can improve the bond rating and attract investors to make purchases. Meanwhile, the firm's ability to pay short-term debt does not affect the bond rating, because bonds include long-term liabilities. While the firm's ability to generate profits and also the firm's funding policy can affect the bond rating although not significantly.

5.2. Limitations

Our research object is still limited to banking firm and the use of variables that are thought to affect bond ratings. Future researchers are expected to expand the object of research and add other variables that are thought to strongly influence bond ratings, both micro and macro variables of the firm.

Reference

- Adelia gufita, zaenal arifin. (2022). Pengaruh Rasio Keuangan dan Marturity Terhadap Rating Obligasi Pada Perusahaan Yang Terdaftar di BEI, *Selekta Manajemen: Jurnal Mahasiswa Bisnis dan Manajemen*, vol. 01, no. 01, pp. 328–340.
- Angel, G. C., & Sudjiman, L. S. (2020). Pengaruh Leverage dan Profitabilitas terhadap Peringkat Obligasi Perusahaan Sektor Jasa Non Keuangan yang Terdaftar di BEI 2017-2020. *Akuntansi Keuangan*, 1–14.
- Azizah, I., & Ady, S. U. (2023). Profitability, Leverage, Liquidity and Bond Age On Bond Rating. *Ecodemica : Jurnal Ekonomi , Manajemen dan Bisnis*, 7(2), 264–271.
- Brigham, E. F., & Houtson, J. F. (2019). *Fundamentals of Financial Managements 15th Edition (Terjemahan)*. Cengage.

- Darma, M., & Sulistiyani, T. (2020). Pengaruh Profitabilitas, Likuiditas, Ukuran Perusahaan Dan Leverage Terhadap Peringkat Obligasi. *Jurnal Fokus Manajemen Bisnis*, 9(1), 92. <https://doi.org/10.12928/fokus.v9i1.1552>
- Darmawan, A., Al Fayed, Y. F., Bagus, F., & Pratama, B. C. (2020). Pengaruh Profitabilitas, Likuiditas, Leverage, Umur Obligasi dan Ukuran Perusahaan Terhadap Peringkat Obligasi Pada Sektor Keuangan Yang Terdapat Di Bei Tahun 2015-2018. *DERIVATIF: Jurnal Manajemen*, 14(1). <https://doi.org/10.24127/jm.v14i1.443>
- Dewi, M. S., & Utami, E. M. (2020). The influence of profitability and liquidity to bond rating and the impact on the bond yield. *International Journal of Research in Business and Social Science* (2147- 4478), 9(4), 214–219. <https://doi.org/10.20525/ijrbs.v9i4.729>
- Esensia, D., Fathoni, A. F., & Haryetti. (2017). Effect of Financial Performance and Good Corporate Governance of Bond Ratings (A Case Study Companies Listed In Indonesia Stock Exchange Period 2013-2017). *AFEBI Management and Business Review*, 5(2), 50–58.
- Esensia, D., Fathoni, A. F., & Haryetti, H. (2020). Effect of Financial Performance and Good Corporate Governance of Bond Ratings (A Case Study Companies Listed In Indonesia Stock Exchange Period 2013-2017). *AFEBI Management and Business Review*, 5(2), 50. <https://doi.org/10.47312/ambr.v5i2.249>
- Gujarati, D. N. (2003). *Basic Econometrics*. McGraw-Hill Higher Education.
- Hafiz, M., Yetty, F., & Miftah, M. (2021). Analisis Determinan Peringkat Obligasi pada Perusahaan Non Lembaga Keuangan Oleh PT. Pefindo. *Korelasi*, 2(1), 622–635.
- Herlinasari, N. (2021). Dampak Rasio Keuangan Terhadap Peringkat Obligasi Pada Perusahaan Jasa Sektor Konstruksi Yang Terdaftar Di BEI. *Jurnal Ekonomi, Bisnis, dan Akuntansi*, 22(4), 378–389. <https://doi.org/10.32424/jeba.v22i4.1768>
- Hung, S., Ginting, E. S., & Joe, S. (2021). The Effect Of Profitability , Liquidity, Leverage On Bond Rating of Financial Journal of Management Science (JMAS). *Journal of Management Science*, 4(4), 106–112.
- Idawati, I. A. A., Pratama, I. G. S., & Mandasari, I. C. S. (2018). Pengaruh Kinerja Keuangan Terhadap Harga Saham Pada Bank Umum Milik Pemerintah. *Widya Manajemen*, 1(1), 1–17. <https://doi.org/10.32795/widyamanajemen.v1i1.227>
- Izzat Khalqi. (2018). Analisis Pengaruh Profitabilitas, Laverage Dan Ukuran Perusahaan Terhadap Peringkat Obligasi Pada Perusahaan Yang Terdaftar Di BEI dan Diperingkat Oleh Pefindo (Periode 2012-2016). *Indonesia Banking School*, 1–14.
- Kaltsum, H., & Anggraini, D. T. (2021). Analisis Dampak Likuiditas, Leverage, dan Company Size Terhadap Peringkat Obligasi. *Jurnal Akuntansi dan Governance*, 1(2), 79–88.
- Kustiyaningrum, D., Nuraina, E., & Wijaya, A. L. (2017). Pengaruh Leverage, Likuiditas, Profitabilitas, Dan Umur Obligasi Terhadap Peringkat Obligasi (Studi Pada Perusahaan Terbuka Yang Terdaftar Di Bursa Efek Indonesia). *Assets: Jurnal Akuntansi dan Pendidikan*, 5(1), 25. <https://doi.org/10.25273/jap.v5i1.1184>
- Lestari, E. (2019). Analisis Kinerja Keuangan Berbasis Rasio Pada Perusahaan Bachri Darmo Kota Malang (Studi Kasus Perusahaan Bachri Darmo Kota Malang/Area Malang). *Optima*, 2(2), 7. <https://doi.org/10.33366/opt.v2i2.1165>
- Mahirun, M. (2019). Creation of Investment Opportunities through Increased Sales. *QUALITY Access to Succes*, 20(171), 76–81.
- Mahirun, M., Jannati, A., Kushermanto, A., & Prasetyani, T. R. (2023). Impact of Dividend Policy on Stock Prices. *Acta Logistica*, 10(2), 199–208.
- Mardiana, Y., & Suryandani, W. (2021). Pengaruh Likuiditas, Leverage, Profitabilitas, Dan

- Jaminan Terhadap Peringkat Obligasi Pada Perusahaan Non Keuangan Yang Diperingkat Oleh Pt Pefindo Yang Terdaftar Di Bursa Efek Indonesia. *Journal of Global Business and Management Review*, 3(1), 30. <https://doi.org/10.37253/jgbmr.v3i1.5089>
- Muhammad Rezky. (2013). *Pengaruh Profitabilitas, Likuiditas, Leverage, Ukuran Perusahaan, dan Umur Obligasi Terhadap Peringkat Obligasi Pada Perusahaan-Perusahaan Go Public Yang Terdaftar Di Bei Periode 2010-2013*. 1–26.
- Nurhariyaningsih, I., & Nazar, M. R. (2020). The Effect of Financial Performance on Obligation Retings. *E-Proceedings of Management*, 7(2), 2988–2992.
- Nuriman, F. E., & Nurdiansyah, D. H. (2021). Pengaruh Rasio Profitabilitas, Likuiditas, Dan Solvabilitas Terhadap Peringkat Obligasi Syariah (SUKUK). *Journal of Economic, Bussines and Accounting (COSTING)*, 4(2), 801–808. <https://doi.org/10.31539/costing.v4i2.1706>
- Oktaviyani, R. D. (2021). Effect of Profit Management, Financial Ratio and Corporate Governance Mechanism on Bond Rating. *Jurnal Ekonomi*, 10(02), 51–59. <https://doi.org/10.54209/ekonomi.v10i02.145>
- Pandutama, A. (2012). Faktor-Faktor Yang Mempengaruhi Prediksi Peringkat Obligasi Pada Perusahaan Manufaktur Di BEI. *Jurnal Ilmiah Mahasiswa Akuntansi*, 1(4), 49–55.
- Prastiani, S. C. (2018). Pengaruh Kinerja Keuangan Terhadap Peringkat Obligasi Dengan Manajemen Laba Sebagai Variabel Intervening Pada Perusahaan Manufaktur Yang Terdaftar Di BEI. *Jurnal Akuntansi Berkelanjutan Indonesia*, 1(1), 1. <https://doi.org/10.32493/jabi.v1i1.y2018.p1-23>
- Risawati. (2020). Factor Analysis-Growth , Size, Profitability, Liquidity Factors on Bond Rating. *International Journal of Social and Management Studies*, 01(01), 117–122.
- Rivandi, M., & Gustiyani, W. (2021). Pengaruh leverage, Likuiditas dan Profitabilitas Terhadap Peringkat Obligasi Pada Perusahaan Manufaktur Yang Terdaftar di PT. Pefindo Periode 2015-2019. *Jurnal Ilmiah Pendidikan Scholastic*, 5(1), 130–139. <https://doi.org/10.36057/jips.v5i1.456>
- Rosita, N., Sholichah, M., & Santoso, R. A. (2022). Determinan Peringkat Obligasi Korporasi di Indonesia. *Fair Value: Jurnal Ilmiah Akuntansi Dan Keuangan*, 5(3), 1333–1346. <https://doi.org/10.32670/fairvalue.v5i3.2457>
- Rusdianto, Hidayat, W., Tjaraka, H., Septiarini, D. F., Fayanni, Y., Utari, W., Waras, Indrawati, M., Susanto, H., Thahjo, J. D. W., Mufarokhah, N., Susetyorini, Elan, U., Samsi, N., Choiri, Syamsul, M., Widodo, M., Suyanto, H., Zainal, M., & Imanawati, Z. (2020). The Effect of Earning Per Share, Debt To Equity Ratio and Return On Assets on Stock Prices: Case Study Indonesian. *Academy of Entrepreneurship Journal*, 26(2), 1–10.
- Ruspriono, & Marsoem, B. S. (2021). Factors Affecting Corporate Bond Ratings in Indonesia. *Journal of Business and Management Studies*, 3(2), 98–107. <https://doi.org/10.32996/jbms>
- Setiawan, A., Tubastuvi, N., Septin Muji R, T., & Yustina Rahmawati, I. (2022). Pengaruh Kinerja Keuangan Terhadap Peringkat Obligasi Dimediasi Oleh Earning Management Pada Sektor Non Keuangan 2018-2020. *Jurnal Ilmiah MEA (Manajemen, Ekonomi, dan Akuntansi)*, 6(1), 189–206.
- Setiawan, I. G. A. N. A. P., & Mahardika, D. P. K. (2019). Analisis Pengaruh Market to Book Value, Firm Size dan Profitabilitas Terhadap Pengambilan Keputusan Lindung Nilai (Studi Kasus Pada Perusahaan Sub Sektor Otomotif dan Komponennya Yang Terdaftar Di Bursa Efek Indonesia Pada Tahun 2014–2017). *Jurnal Ilmiah Akuntansi*,

- 4(1), 124–140. <https://doi.org/10.23887/jia.v4i1.17055>
- Sri, R. R., & Dwi, A. (2009). *Pengaruh Ukuran Perusahaan Terhadap*. 11(1), 33–56.
- Suharmadi, S., & Suropto, S. (2021). Effect of Liquidity, Productivity and Firm Size on Bond Ranking. *International Journal of Environmental, Sustainability, and Social Science*, 2(2), 79–88.
- Sulaksono, B., & Sandra, I. (2022). Pengaruh Rasio Keuangan, Kepemilikan, Kebijakan Dividen dan Ukuran Perusahaan Terhadap Nilai Perusahaan. *Jurnal Ilmu dan Riset Akuntansi*, 2(1), 25–34.
- Sulistiani, & Meutia, R. (2021). Pengaruh Ukuran Perusahaan, Profitabilitas, Likuiditas dan Leverage Terhadap Peringkat Obligasi pada Perusahaan Jasa Keuangan di Bursa Efek Indonesia. *Jurnal Ilmiah Mahasiswa Ekonomi Akuntansi (JIMEKA)*, 6(2), 162–177.
- Suprpto, R. A., & Aini, N. (2019). Prediksi Peringkat Obligasi: Profitabilitas, Leverage, Likuiditas dan Ukuran Perusahaan pada Perusahaan Non Keuangan yang Terdaftar di Pefindo Tahun 2013-2017. *Fakultas Ekonomika dan Bisnis Universitas Stikubank Semarang*, 8(1), 78–89.
- Suryani Ulan Dewi, N. L. P., & Sudiarta, I. G. M. (2018). Pengaruh Profitabilitas, Likuiditas, Leverage, dan Ukuran Perusahaan Terhadap Return Saham Pada Perusahaan Food and Beverage. *E-Jurnal Manajemen Universitas Udayana*, 8(2), 932. <https://doi.org/10.24843/ejmunud.2019.v08.i02.p13>
- Syahrian Utami, B. E. F., Sasanti, E. E., & Zuhrotul Isnaini. (2021). Determinan Peringkat Obligasi Perusahaan Non Keuangan Yang Terdaftar Di BEI Periode 2014-2018. *Jurnal Riset Mahasiswa Akuntansi*, 1(3), 73–94. <https://doi.org/10.29303/risma.v1i3.97>
- Tambunan, S. B., Sari, W. P., Saribu, A. L. N. D., Prayudi, A., Rosalina, D., & Yusnaini. (2023). Determining Factors For Moderating Leverage Bond Ratings. *Jurnal Akuntansi Trisakti*, 10(1), 117–136.
- Wibowo, A. E., & Linawati, L. (2020). Pengaruh Likuiditas, Profitabilitas Dan Leverage Terhadap Peringkat Obligasi Perusahaan Di Indonesia. *Jurnal Riset Manajemen Sekolah Tinggi Ilmu Ekonomi Widya Wiwaha Program Magister Manajemen*, 7(2), 143–152.